



BAKER HYDRO

# ONYX FILTER

*Superior strength and dependability*



Designed to cope with the cyclic pressures of the modern day swimming pool, Onyx filter vessels are precision injection moulded for superior strength and dependability.

Onyx filters are ideal for pools equipped with in floor cleaning systems and high powered pumps.

- Granular media filtration
- Multiport valve for ease of use
- Pressure rated at 350 kPa
- Corrosion and UV resistant



## Superior Strength

Onyx filters are considered one of the strongest filters within its class. Its filter vessel is precision injection moulded within minimal tolerances for enhanced structural strength.

Pressure rated at 350 kPa, Onyx filters are ideal for pools equipped with in floor cleaning systems and high powered pumps.

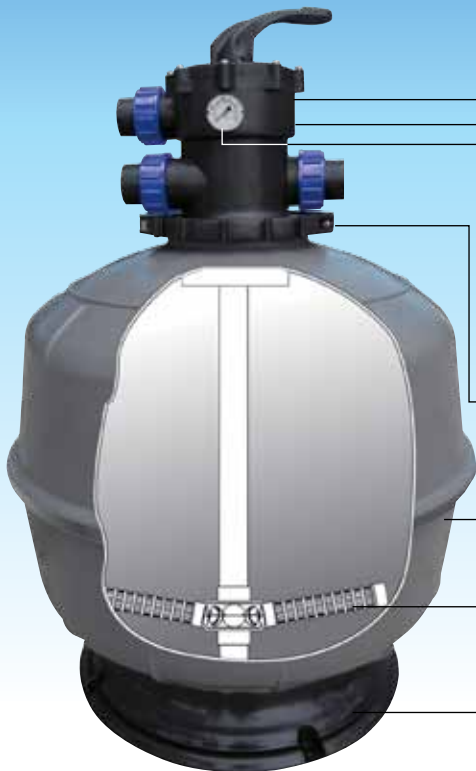

Multiport valve with ergonomic handle and quick connect barrel unions

Clear sight glass for backwash inspection

Pressure gauge to determine the filter's capacity

Multiport valve clamp provides 360° orientation of the Multiport valve for simple installation and service

UV and corrosion resistant

Hydraulically balanced flow distribution, to maximise filtration and backwashing

Large filter base for stable floor mounting

Maximum working temperature of 50°C

## Ease of Maintenance

Cleansing the filter simply requires turning the filter's multiport lever from the "filter" position to the "backwash" position, which reverses the flow of water in the filter, flushing the filter bed.

### Filter Mode

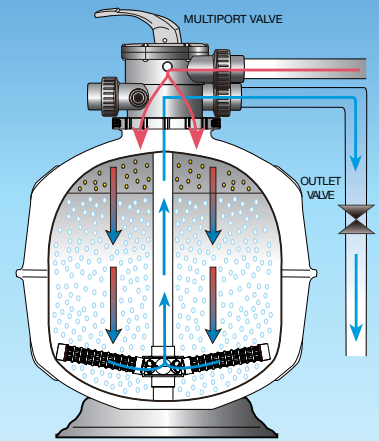

### Backwash Mode

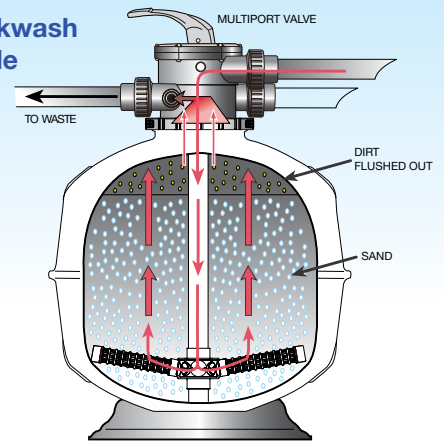

## Technical Specification

Model No.	Valve Size (mm)	Inner Dia. (mm)	Filter Area (sq. m <sup>2</sup> )	Bed Depth (mm)	Max. Flow* (lpm)	Max. Pool Size (litres)	Min. Backwash (lpm)	Media Volume (litres)	Sand 16/30 (kg)	Zeolite 1 - 2.2 (kg)
Onyx 600	40	600	0.28	250	226	81,000	189	89	130	107

## Dimension (mm)

Model	Valve Size	A	B	C	D	E	F	G	H	V	K
Onyx 600	40	942	650	484	182	655	799	708	88	560	115

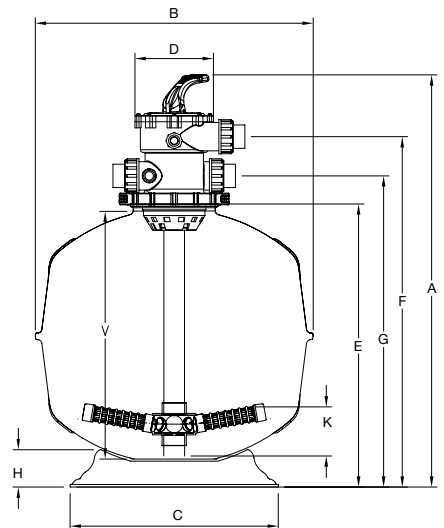

## Warranty

Onyx filters are covered by a 10-year tank warranty and 1-year warranty on all other components. Commercial installations are covered by a 5-year (1 year full + 4 years pro rata) tank warranty and 1-year warranty on all other components.

Please refer to Baker Hydro's warranty terms & conditions.



The LEADER In Filtration and  
Water Treatment For Over 50 Years

[www.bakerhydro.com](http://www.bakerhydro.com)

**NSW**  
Sydney (Head Office)  
Tel: (02) 9898 8686  
Fax: (02) 9898 1754

**QLD**  
Brisbane  
Tel: (07) 3299 9900  
Fax: (07) 3299 9911

**VIC/TAS**  
Melbourne  
Tel: (03) 9764 1211  
Fax: (03) 9764 0577

**WA**  
Perth  
Tel: (08) 9273 1900  
Fax: (08) 9273 1999

**SA / NT**  
Adelaide  
Tel: (08) 8244 6000  
Fax: (08) 8244 6011

**Waterco (NZ)**  
Auckland  
Tel: (09) 525 7570  
Fax: (09) 525 6580